

CLASS 1&2

BJT

TRANSISTORS

Transistor is a multifunction semiconductor device that when connected with other circuit elements is able to produce current gain, voltage gain and signal power gain. Hence, the transistor is known as an active device whereas the diode is a passive device.

TYPES OF TRANSISTORS

Typical:

1. **BJT-Bipolar Junction Transistor**
2. **FET-Field Effect Transistor:**
 - **JFET-Junction Field Effect Transistor**
 - **MOSFET-Metal-oxide-semiconductor FET**

- **BJT is a 3-terminal device.**
- **The basic operation of a BJT is based on the current control of one terminal by the voltage applied across the other two terminals. Thus, the BJT is a voltage controlled current source.**
- **BJT has 3 doped regions and 2 p-n junctions. As both holes and electrons are involved in the operation of this device, the BJT is called bipolar.**
- **For the FET, only the majority carriers contribute to the current flow. Hence, the FET is a unipolar device.**

Cross-section of a p-n-p BJT:

- Starts with the p-substrate
- n-region is thermally diffused through the opening in the oxide into the p-substrate
- p⁺ (heavily doped) region is diffused into the n-region
- Metal contacts are connected to the p⁺ and n through the opening in the oxide layer, while for the p, the metal contact is connected at the bottom layer.

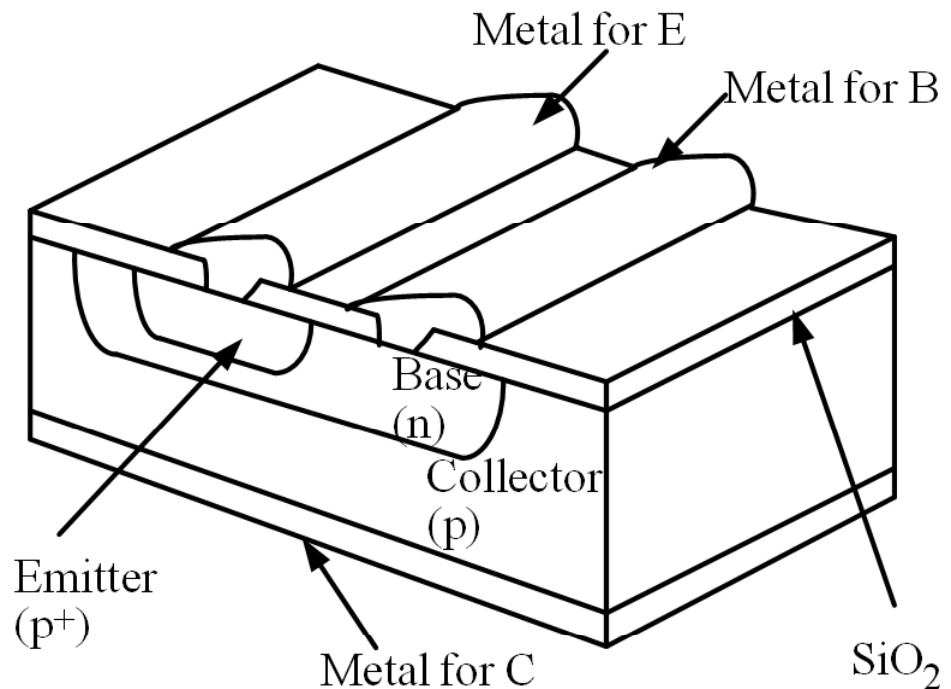

BJT

Has 3 separated doped regions and 2 p-n junctions.

2 types of BJT:

- npn

Simple block diagram of the npn and the npn symbol:

- pnp

Simple block diagram of the pnp and the pnp symbol:

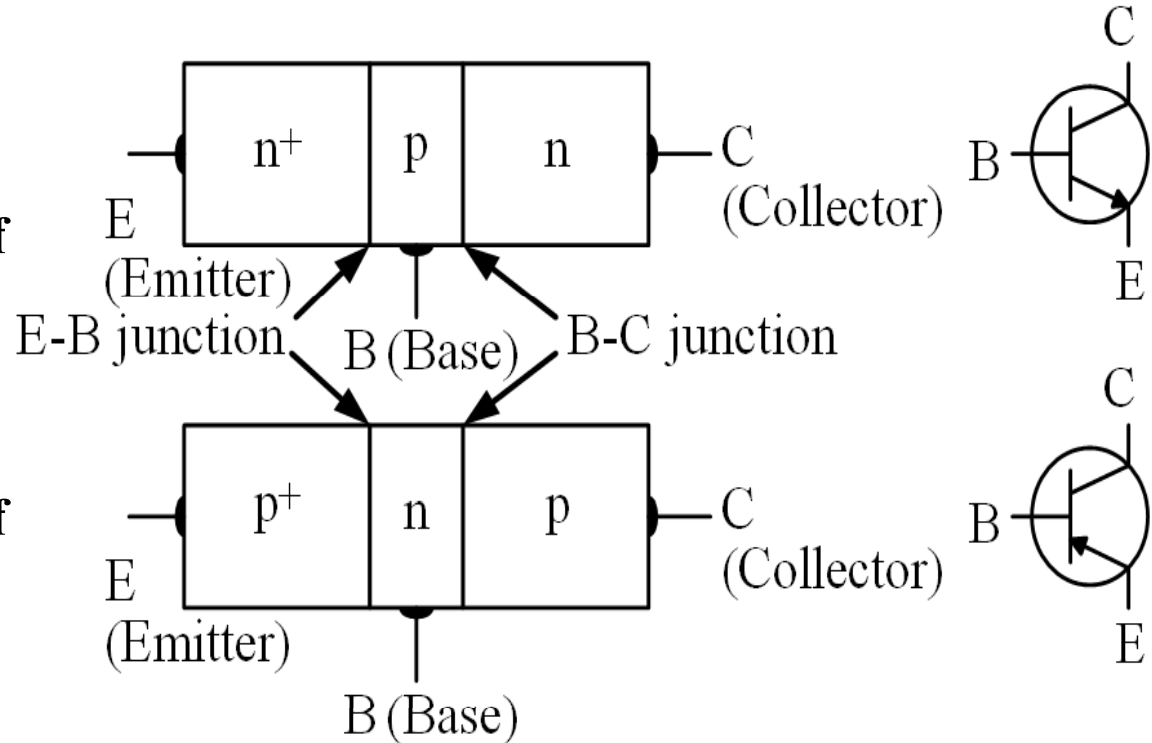

The width of the B is smaller compared to the diffusion length of the minority carriers.

From Thomas L.Floyd, 'Electronic Devices', Sixth Edition, Prentice Hall

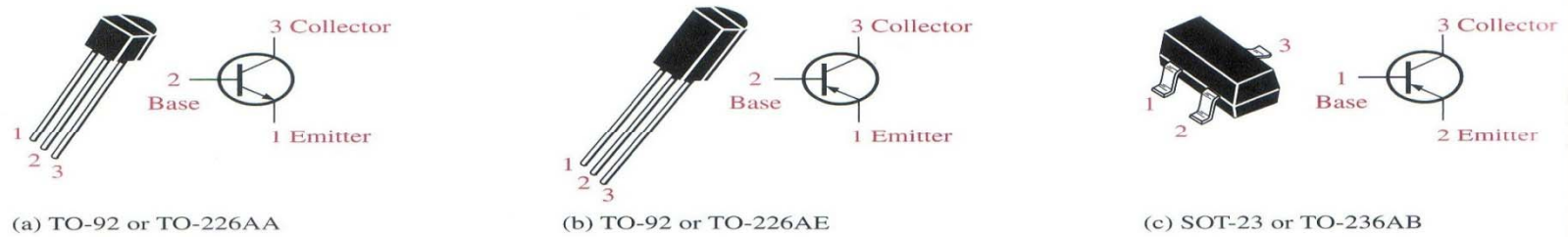

▲ FIGURE 4-25

Plastic cases for general-purpose/small-signal transistors. Both old and new JEDEC TO numbers are given. Pin configurations may vary. Always check the data sheet.

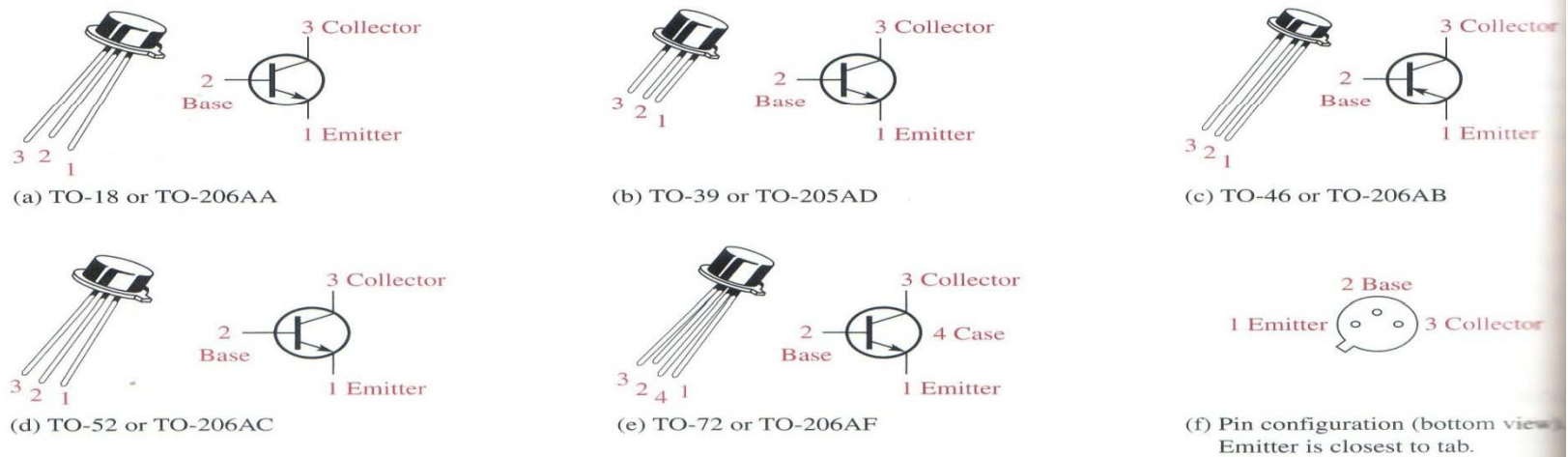

▲ FIGURE 4-26

Metal cases for general-purpose/small-signal transistors.

From Thomas L. Floyd, 'Electronic Devices', Sixth Edition, Prentice Hall

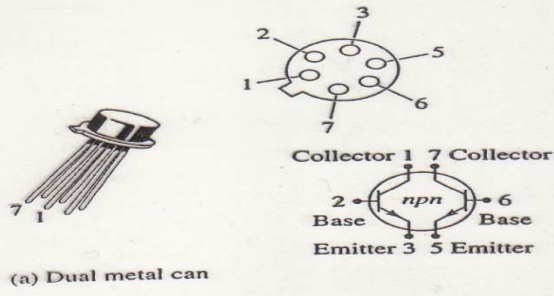

(a) Dual metal can

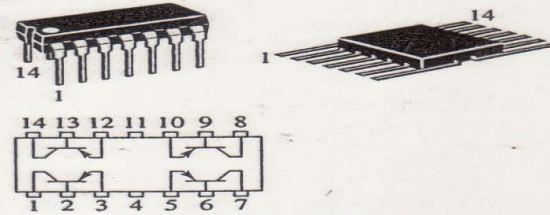

(b) Quad dual-in-line (DIP) and quad flat-pack. Dot indicates pin 1.



(c) Quad small outline (SO) package for surface-mount technology

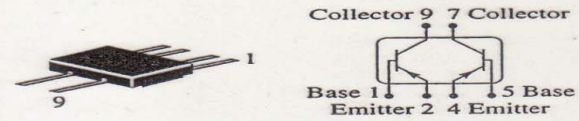

(d) Dual ceramic flat-pack

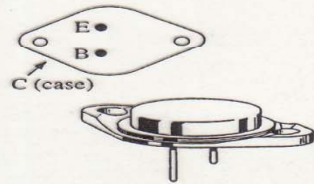

(a) TO-3 or TO-204AE



(b) TO-218

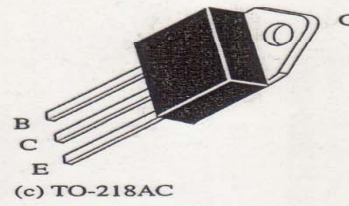

(c) TO-218AC

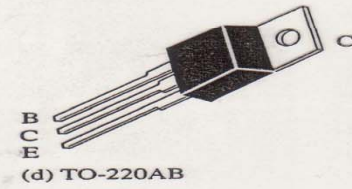

(d) TO-220AB

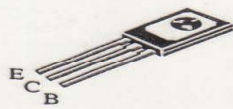

(e) TO-225AA

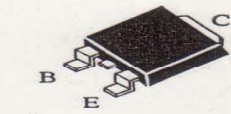

(f) Surface-mount technology

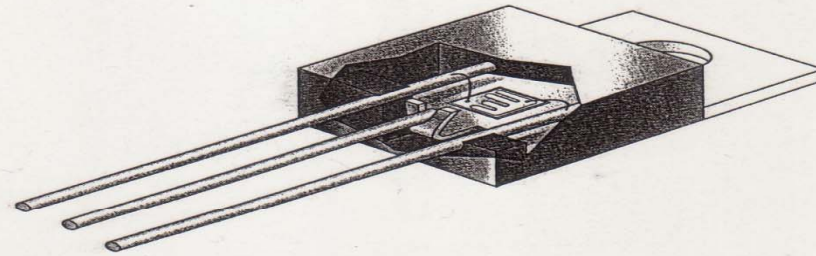

(g) Greatly enlarged cutaway view of tiny transistor chip mounted in the encapsulated package

BASIC OPERATION OF A BJT

- **Basic operation of a BJT is as an amplifier, i.e. the transistor provides voltage gain and/or current gain to the input AC signal.**
- **To ensure that the transistor operates as an amplifier, the transistor must be DC biased.**
- **Condition for the BJT to operate as an amplifier:**
B-E junction is fb
B-C junction is rb

BJT biasing circuits for normal operation as amplifiers are as shown:

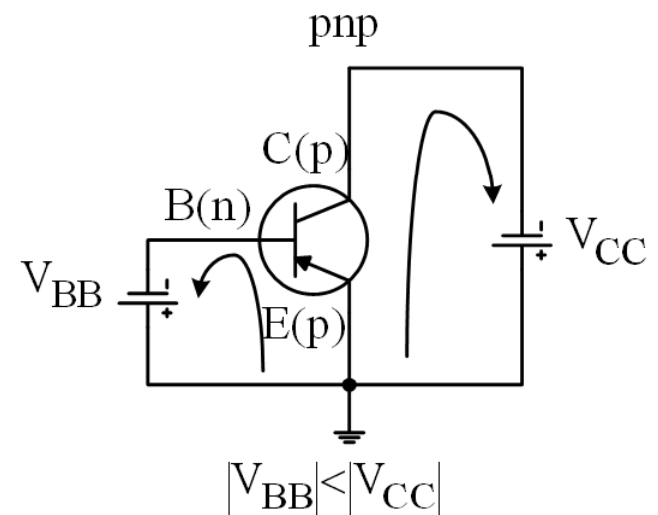
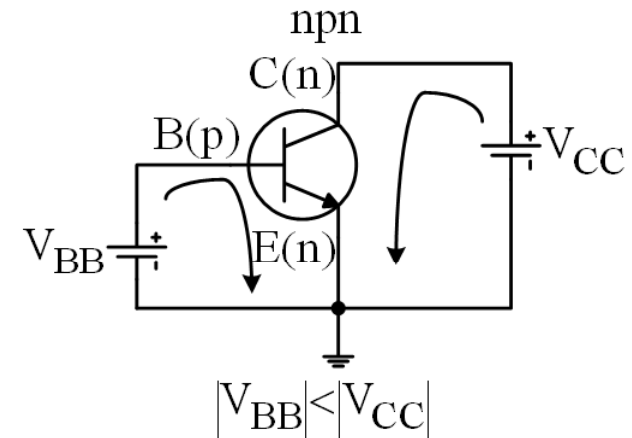

Important currents and voltages

The arrow's direction for current shows the flow of current under normal operation condition (active mode).

$$I_E = I_B + I_C$$

If the value of 2 currents are known, the 3rd current can be calculated.

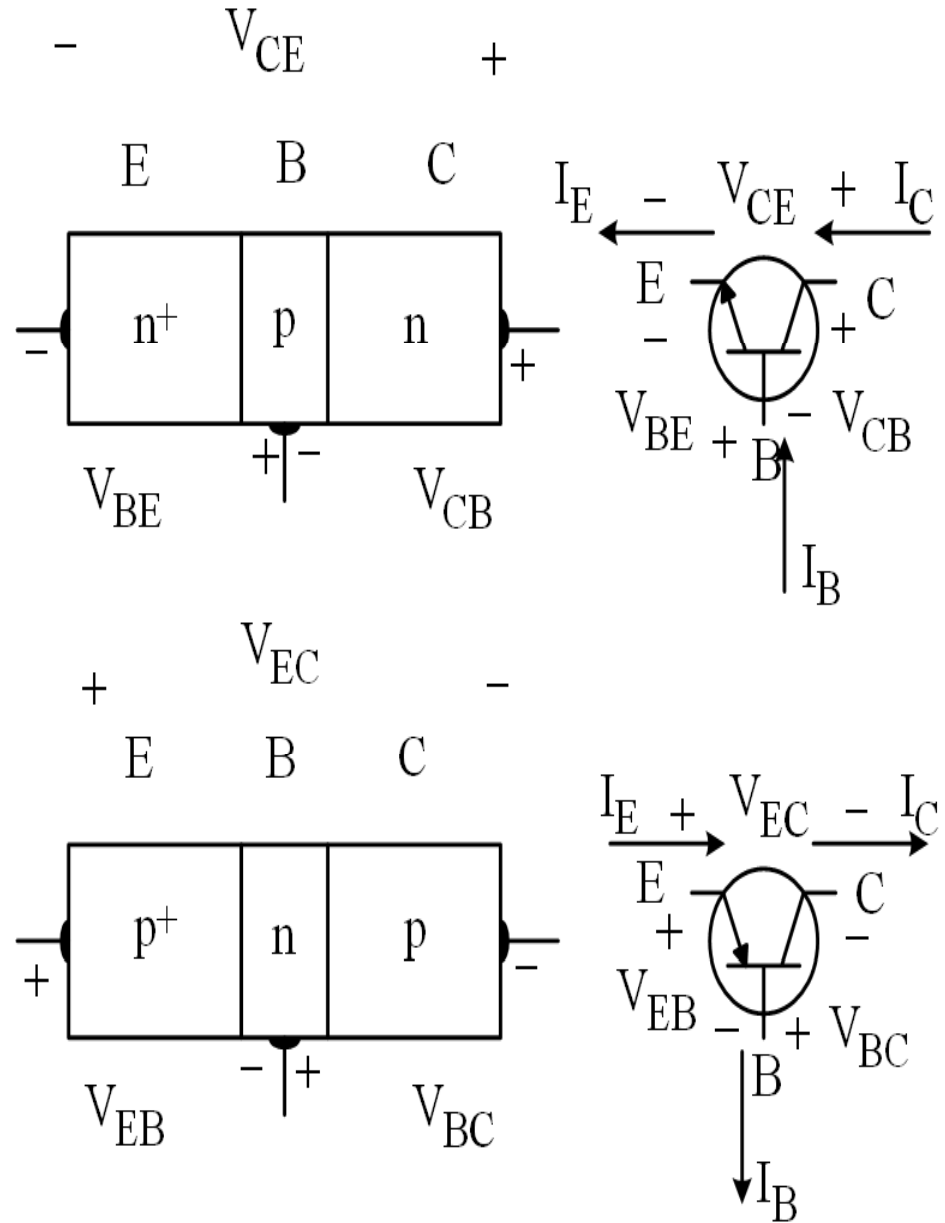

BJT under thermal equilibrium condition. All 3 terminals are connected to ground. There is no difference in voltage between the 3 regions.

Under thermal equilibrium condition, the total current flowing across the p-n junction is 0. Fermi level is constant in all 3 regions.

Bandgap:

$$E_{Cp} - E_{Vp} = E_{Cn} - E_{Vn} = E_g$$

Energy level shift (which is the potential energy of the electrons at the junction):

$$E_{Cp} - E_{Cn} = E_o$$

$$E_{Vp} - E_{Vn} = E_o$$

$$E_o = qV_o$$

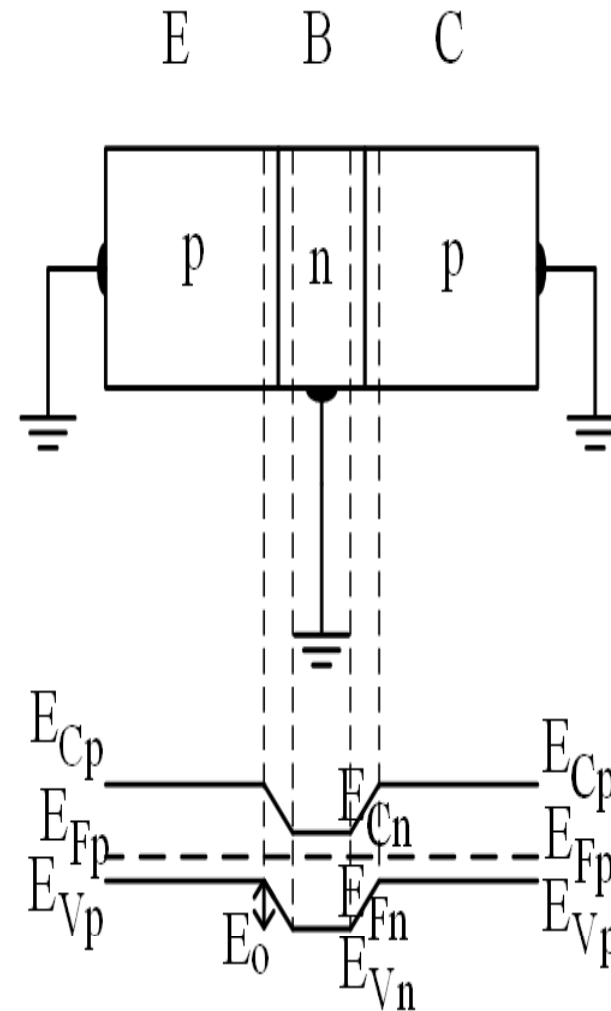

Energy band diagram of the unbiased pnp

Under fb condition, potential energy at the junction reduces. Energy needed by the majority carriers to overcome the potential barrier ↓

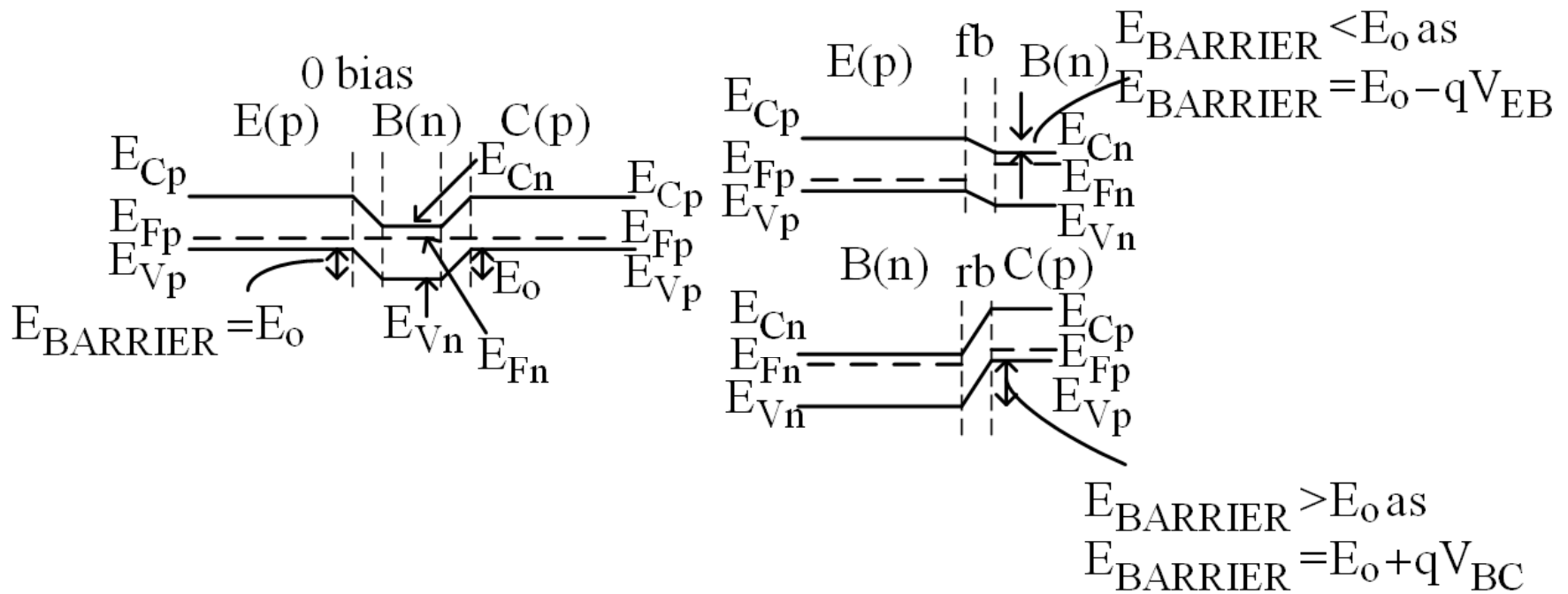
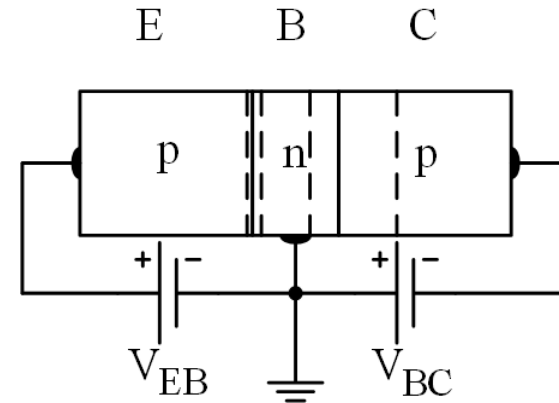

- For the fb EB, depletion region becomes narrower as the holes will neutralize some of the fixed $-ve$ ions. Built in potential \downarrow . Easier for the majority carriers to overcome the built in potential and produce current.
- For the rb BC, depletion region becomes wider. Built in potential \uparrow . Difficult for the majority carriers to overcome the built in potential and produce current. However, the minority carriers contribute to a small reverse current.

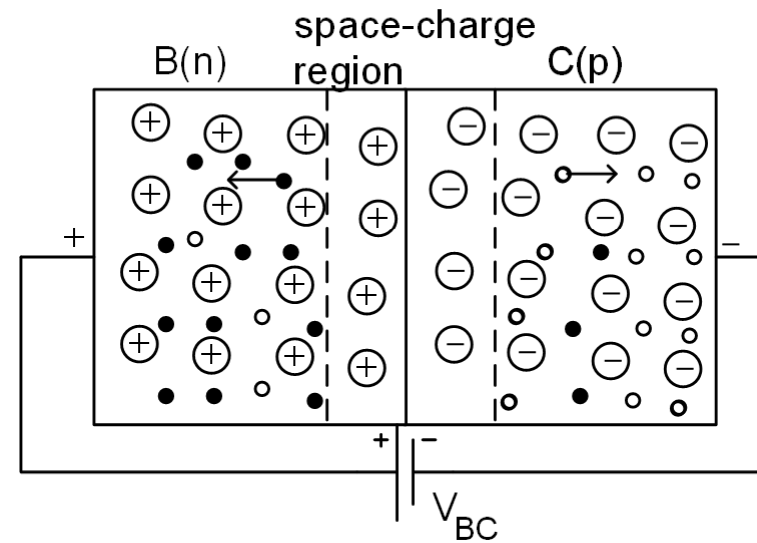
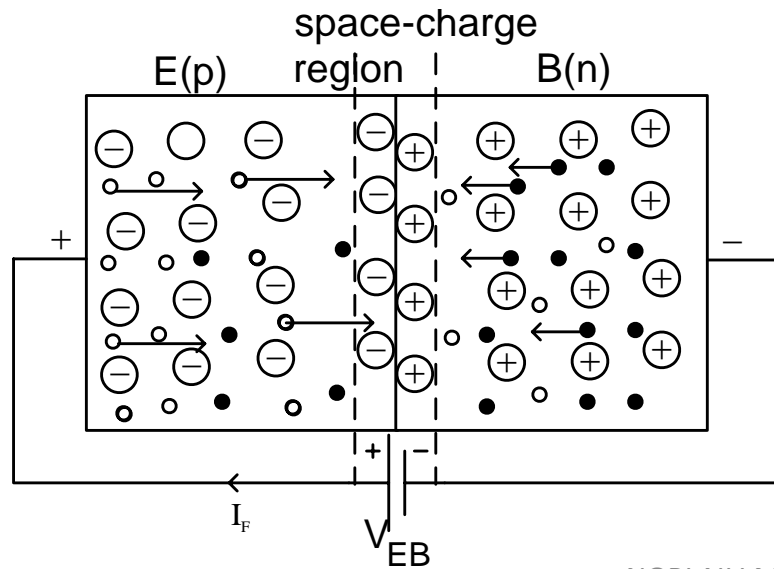
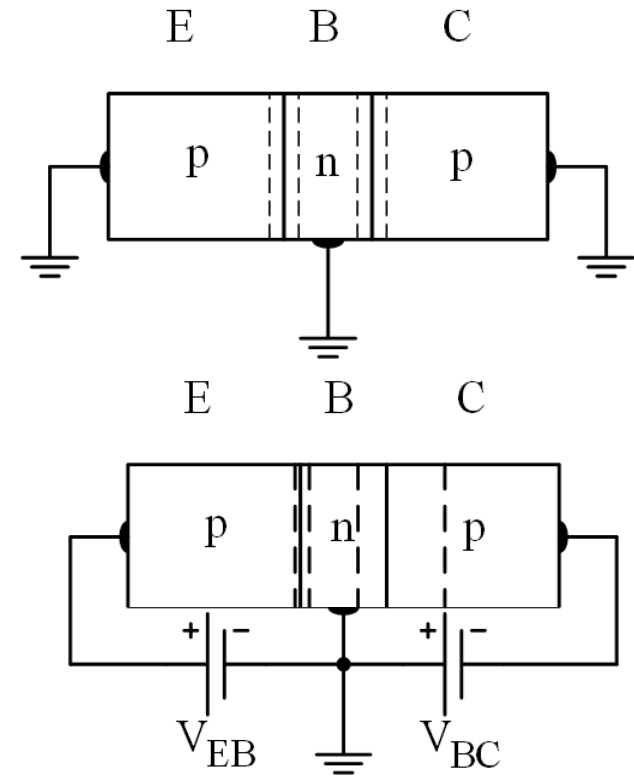

- **EB junction fb and BC junction rb.**
- **B has a very narrow width.**
The number of holes moving from E to B is much more than the number of electrons moving from B to E.
- **Holes in the B are swept into C by the electric field at BC.**

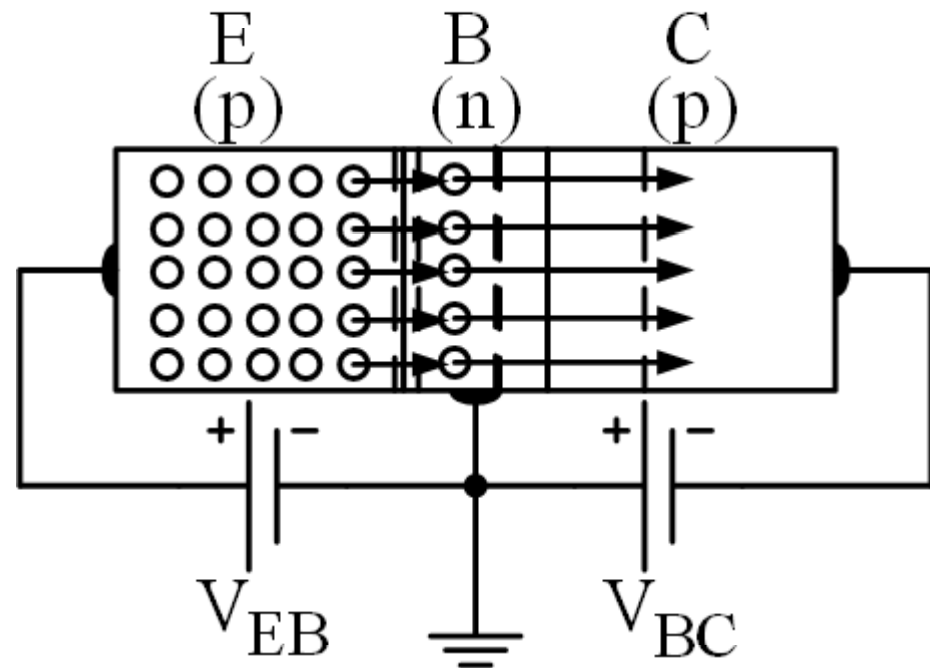

- **CB junction is rb. A small reverse saturation current will flow across the junction.**
- **If the width of B is very narrow, the holes injected from E will diffuse across B and reach the edge of the depletion region BC. They will then be swept into C.**
- **Such operation results in the E being known as Emitter that emits or injects carriers. C is known as Collector that collects carriers.**
- **If many of the holes injected from E reach C without many of them recombining with electrons in B, then the C hole current is \approx the E hole current.**

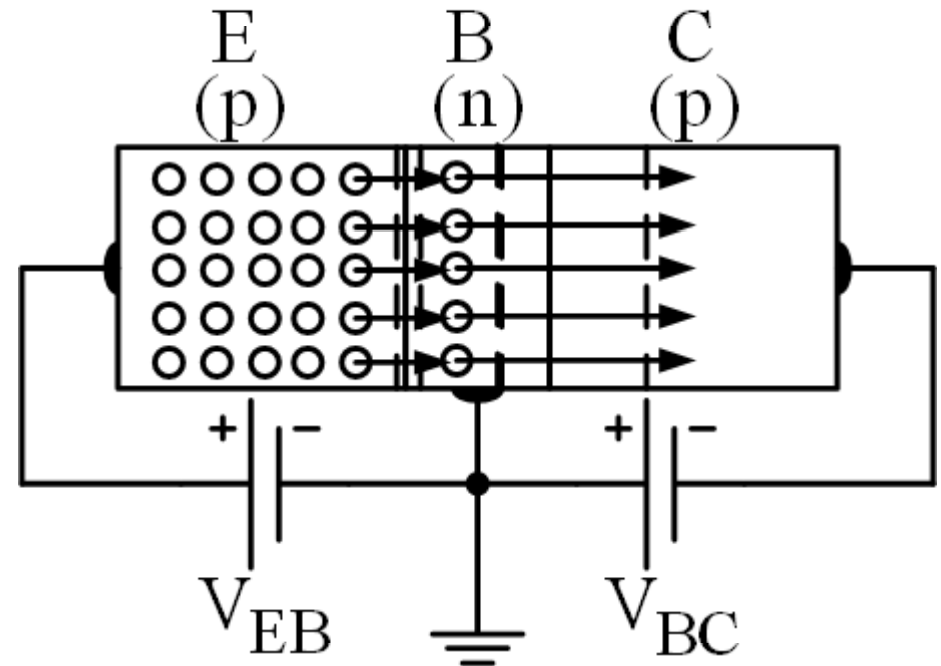

- The depletion layer width of the EB is narrower and the depletion layer width of the BC is wider than the depletion layer width when the transistor is unbiased.
- Since the EB is fb, holes are emitted from E to B and electrons from B to E. Under ideal condition, no generation-recombination are occurring in the depletion region when $V_{EB} > V_o$.
- Emitter current, I_E , is generated by both of these current components, i.e. holes from E to B and electrons from B to E.

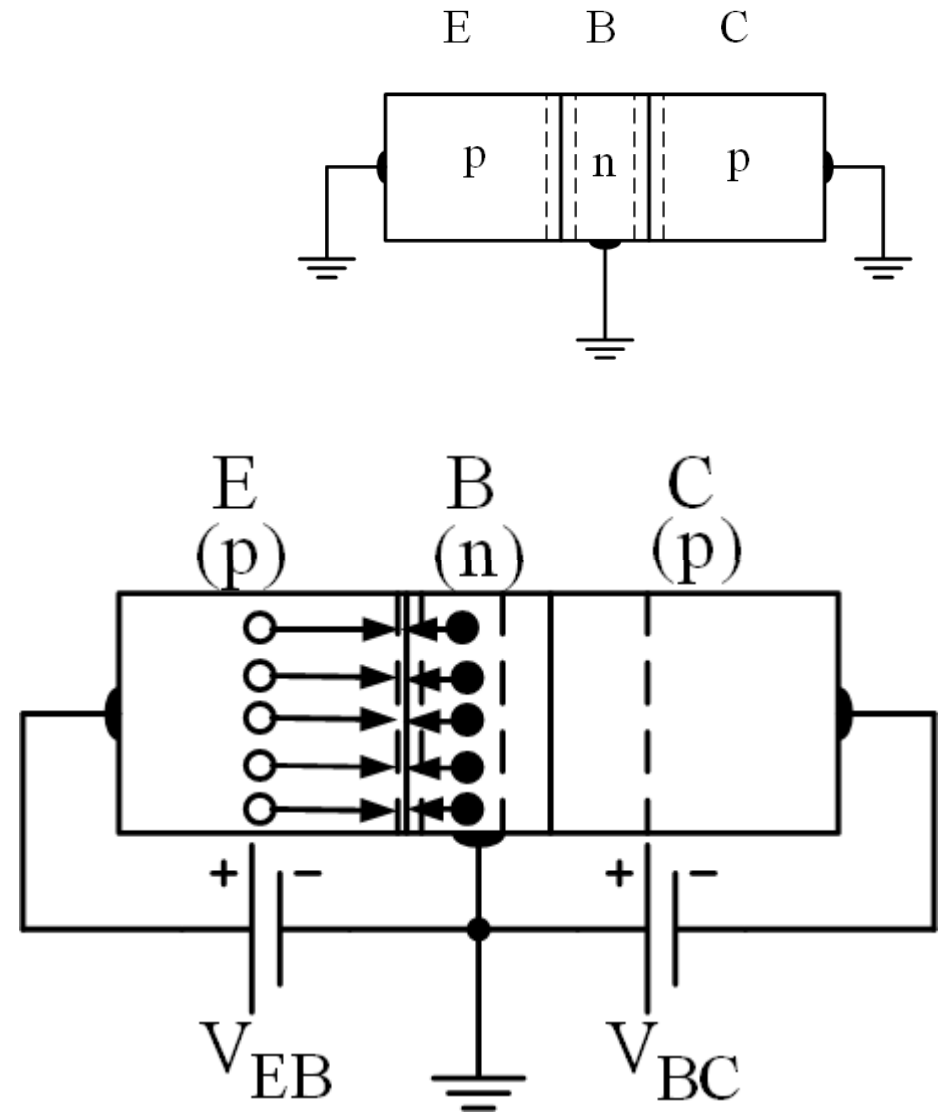

- Carriers which are injected from a nearby E can generate a large current that flows through the rb C junction.
- This is the characteristic of the transistor that can only be realized if the 2 junctions are very close together. The 2 junctions are called interacted p-n junction.
- If the 2 junctions are far from each other, all of the injected holes will be recombined with the electrons in B before reaching BC junction. As a result, the previously mentioned characteristic will not happen. Hence, the width of B must be very narrow.

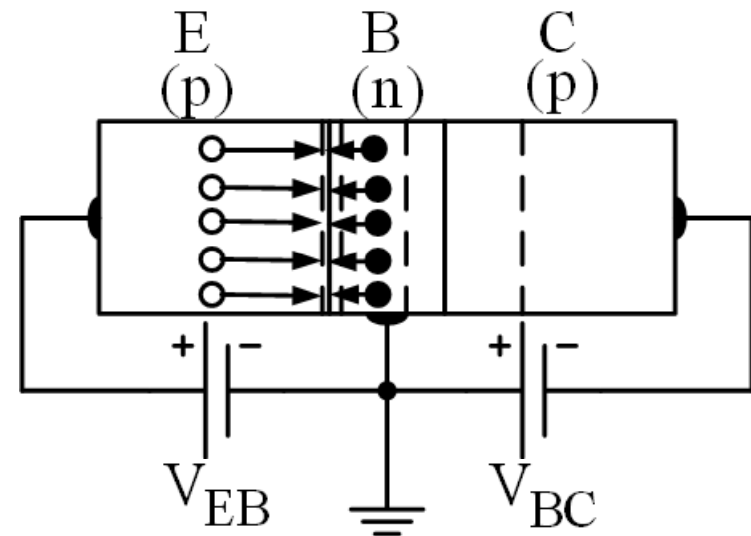

- The diagram shows the ideal doping profile for an npn BJT uniformly doped.
- The impurity doping concentration is typically 10^{19} , 10^{17} and 10^{15} , cm^{-3} for E, B and C respectively.
- The width of B is small compared with the minority carrier diffusion length.
- BJT is not a symmetrical device, i.e. the impurity doping concentration in E and C is different. The geometry of E and C is also different.

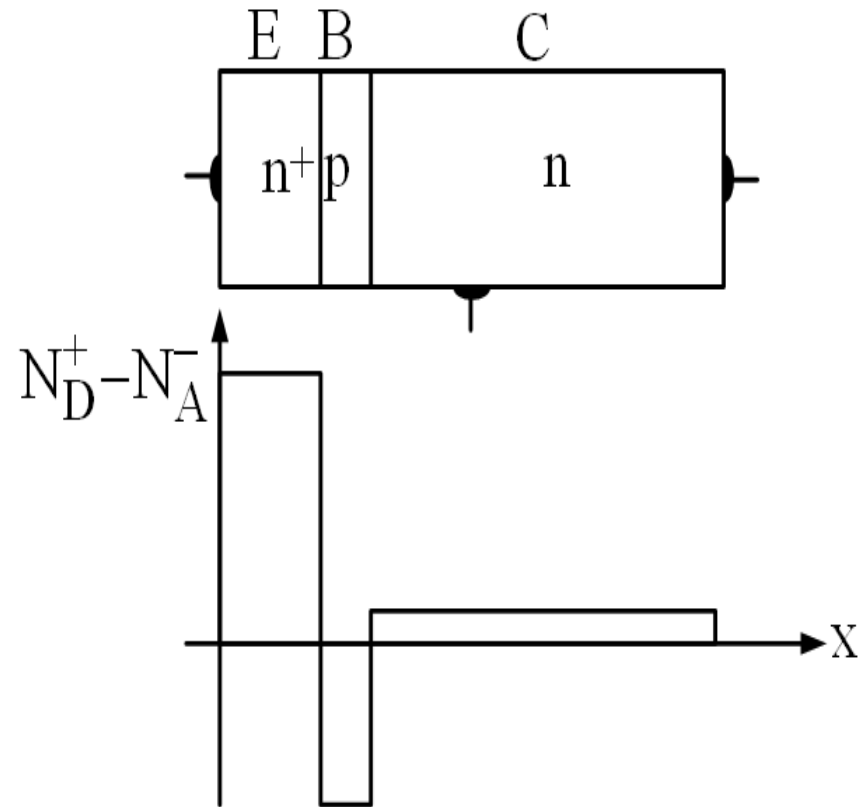

- Holes are injected from E, producing I_{EP} . I_{EP} is the largest current components
- Many of the injected holes will reach the C junction and producing I_{CP} .
- There are 3 Base current components:

1. I_{BB}
2. I_{En}
3. I_{Cn}

I_{BB} is generated by the electrons that need to be supplied to B to replace the electrons that had combined with holes injected from E. I_{BB} is the flow of -ve charges entering B.

$$I_{BB} = I_{EP} - I_{CP}$$

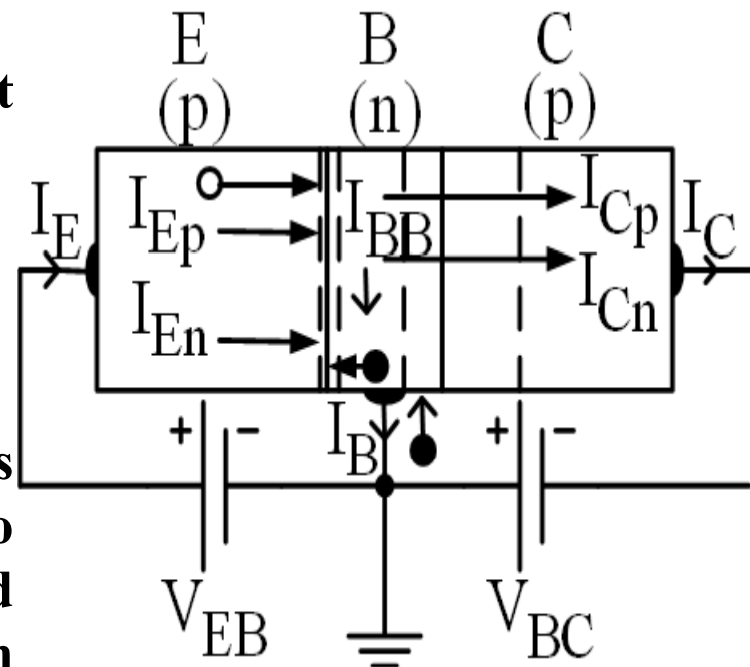

- $I_E = I_{Ep} + I_{En}$
- $I_C = I_{Cp} + I_{Cn}$
- $I_B = I_{BB} + I_{En} - I_{Cn}$
- $I_{BB} = I_{Ep} - I_{Cp}$
- $I_E = I_B + I_C$
- I_{En} = current produced by the electrons injected from B to E
- I_{Cn} = current from the electrons thermally generated near the edge of the C-B junction that drifted from C to B.
- $I_B = I_E - I_C$
- $= I_{Ep} + I_{En} - I_{Cp} - I_{Cn}$
- $= I_{Ep} - I_{Cp} + I_{En} - I_{Cn}$
- $= I_{BB} + I_{En} - I_{Cn}$

